

4

3

2

1

ITEM NO.	DESCRIPTION	QTY.
1	VEE BLOCK	1
2	CLAMP	1
3	HEX BOLT 1/4 UNC X 2" LONG	1

D

D

C

C

B

B

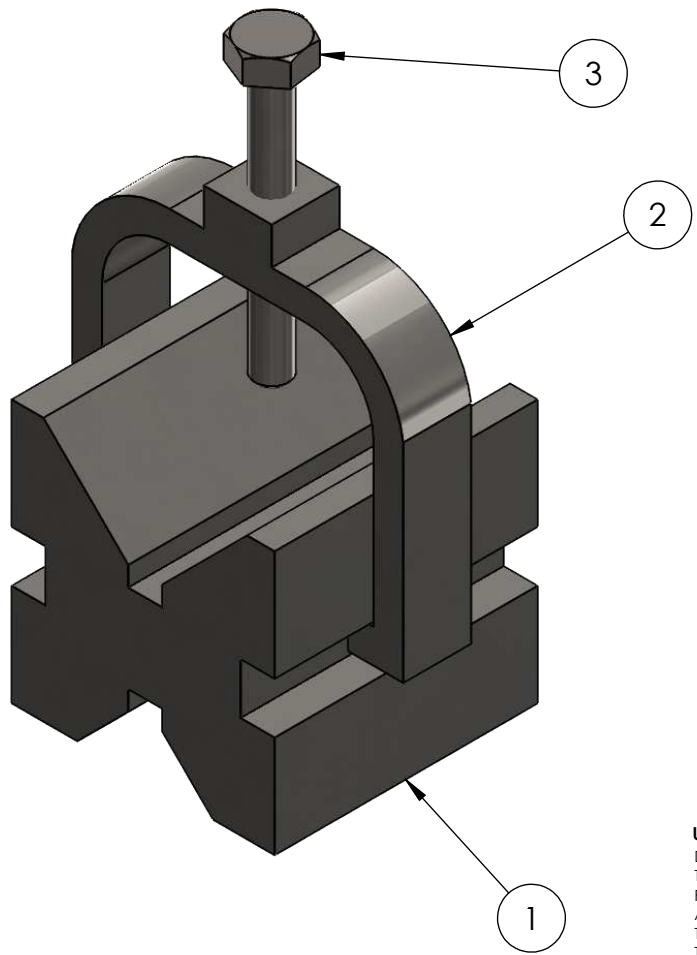

A

A

PROPRIETARY AND CONFIDENTIAL
 THE INFORMATION CONTAINED IN THIS
 DRAWING IS THE SOLE PROPERTY OF
 MAKEITFROMMETAL.COM. ANY NON-
 EDUCATIONAL
 REPRODUCTION IN PART OR AS A WHOLE
 WITHOUT THE WRITTEN PERMISSION OF
 MAKEITFROMMETAL.COM IS
 PROHIBITED.

UNLESS OTHERWISE SPECIFIED:
 DIMENSIONS ARE IN INCHES
 TOLERANCES:
 FRACTIONAL ±1/16
 ANGULAR: MACH ±0.5 BEND ±1
 TWO PLACE DECIMAL ±0.01"
 THREE PLACE DECIMAL ±0.005"

MATERIAL
FINISH

TITLE: VEE BLOCK SET	
SIZE A	DWG. NO. 001
SCALE: 1:1	WEIGHT:
SHEET 1 OF 3	

4

3

2

1

4

3

2

1

NOTES:

- 1. HEAT TREAT TO 56-58 HRC
- 2. VEES TO ALIGN TO CENTER OF BLOCK FROM OUTSIDE SURFACES TO 0.0005"
- 3. MATCH GRIND IN SETS OF 2 OR 4

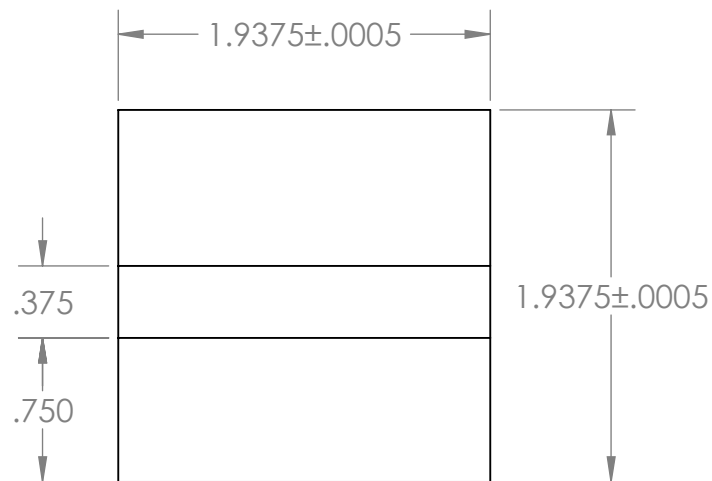
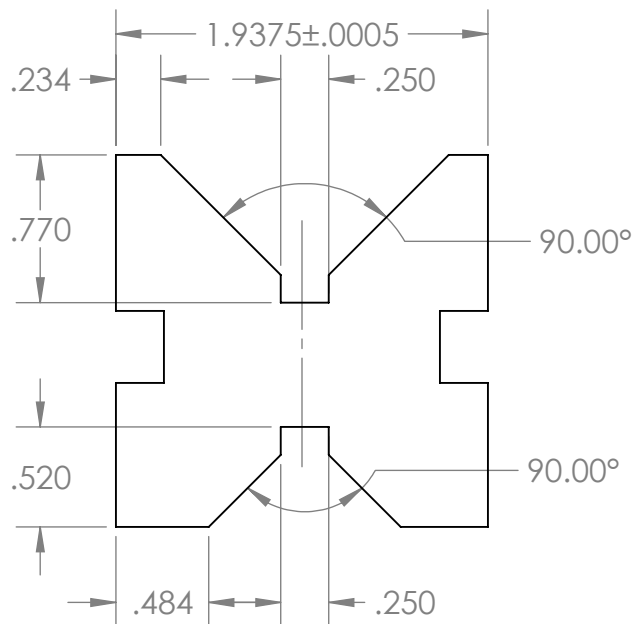

PROPRIETARY AND CONFIDENTIAL
 THE INFORMATION CONTAINED IN THIS
 DRAWING IS THE SOLE PROPERTY OF
 MAKEITFROMMETAL.COM. ANY NON-
 EDUCATIONAL
 REPRODUCTION IN PART OR AS A WHOLE
 WITHOUT THE WRITTEN PERMISSION OF
 MAKEITFROMMETAL.COM IS
 PROHIBITED.

UNLESS OTHERWISE SPECIFIED:

DIMENSIONS ARE IN INCHES
 TOLERANCES:
 FRACTIONAL ±1/16
 ANGULAR: MACH ±0.5 BEND ±1
 TWO PLACE DECIMAL ±0.01"
 THREE PLACE DECIMAL ±0.005"

MATERIAL	4140 STEEL
FINISH	SURFACE GROUND

TITLE: VEE BLOCK	
SIZE A	DWG. NO. 002
SCALE: 1:1	WEIGHT:
SHEET 2 OF 3	

4

3

2

1

D

D

C

C

B

B

A

A

4

3

2

1

D

D

C

C

B

B

A

A

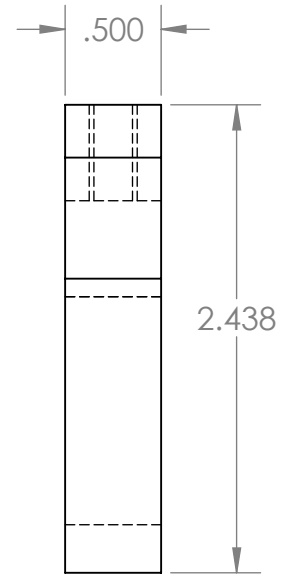
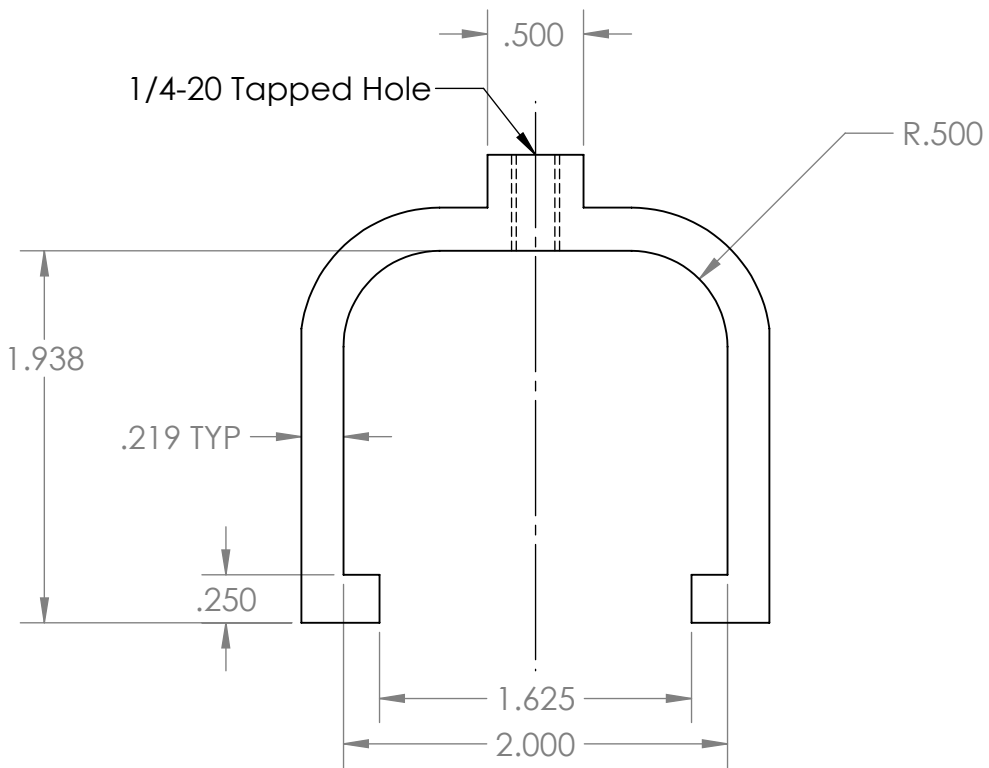

PROPRIETARY AND CONFIDENTIAL
 THE INFORMATION CONTAINED IN THIS
 DRAWING IS THE SOLE PROPERTY OF
 MAKEITFROMMETAL.COM. ANY NON-
 EDUCATIONAL
 REPRODUCTION IN PART OR AS A WHOLE
 WITHOUT THE WRITTEN PERMISSION OF
 MAKEITFROMMETAL.COM IS
 PROHIBITED.

UNLESS OTHERWISE SPECIFIED:
 DIMENSIONS ARE IN INCHES
 TOLERANCES:
 FRACTIONAL ±1/16
 ANGULAR: MACH ±0.5 BEND ±1
 TWO PLACE DECIMAL ±0.01"
 THREE PLACE DECIMAL ±0.005"

MATERIAL	MILD STEEL
FINISH	

TITLE: VEE BLOCK CLAMP	
SIZE A	DWG. NO. 003
SCALE: 1:1	WEIGHT:
SHEET 3 OF 3	

4

3

2

1