

4

3

2

1

ITEM NO.	DESCRIPTION	QTY.
1	BASE	1
2	JAW	1
3	CL-2-SW SPHERICAL WASHER	1
4	NUT	1
5	3/8-16 X 2.25 SHCS	1

D

D

C

C

B

B

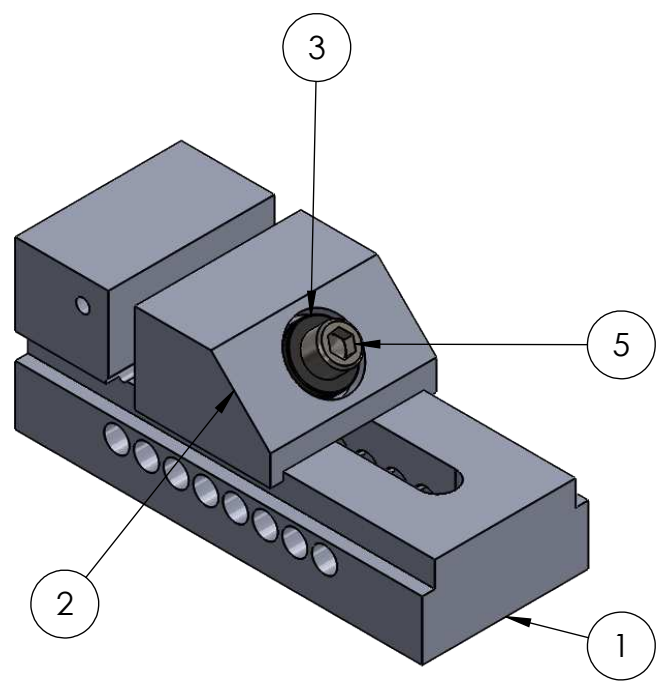
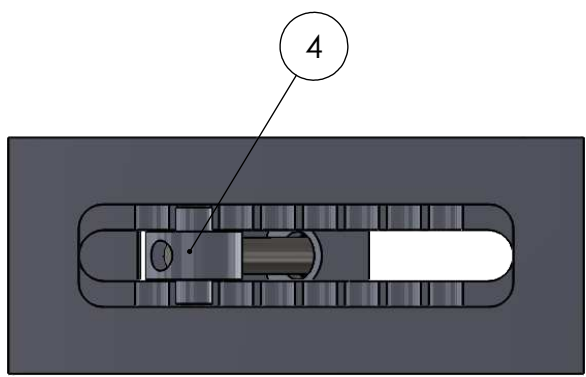

A

A

PROPRIETARY AND CONFIDENTIAL
 THE INFORMATION CONTAINED IN THIS
 DRAWING IS THE SOLE PROPERTY OF
 MAKEITFROMMETAL.COM. ANY NON-
 EDUCATIONAL
 REPRODUCTION IN PART OR AS A WHOLE
 WITHOUT THE WRITTEN PERMISSION OF
 MAKEITFROMMETAL.COM IS
 PROHIBITED.

UNLESS OTHERWISE SPECIFIED:
 DIMENSIONS ARE IN INCHES
 TOLERANCES:
 FRACTIONAL ±1/16
 ANGULAR: MACH ±0.5 BEND ±1
 TWO PLACE DECIMAL ±0.01"
 THREE PLACE DECIMAL ±0.005"

MATERIAL

 FINISH

TITLE: TOOLMAKER'S VISE			
SIZE A	DWG. NO. 001		
SCALE: 1:2	WEIGHT:	SHEET 1 OF 4	

4

3

2

1

4

3

2

1

D

D

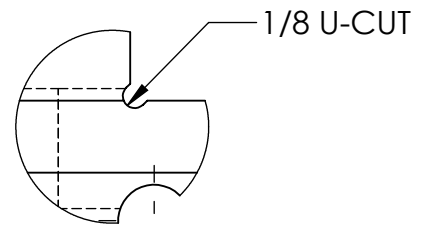
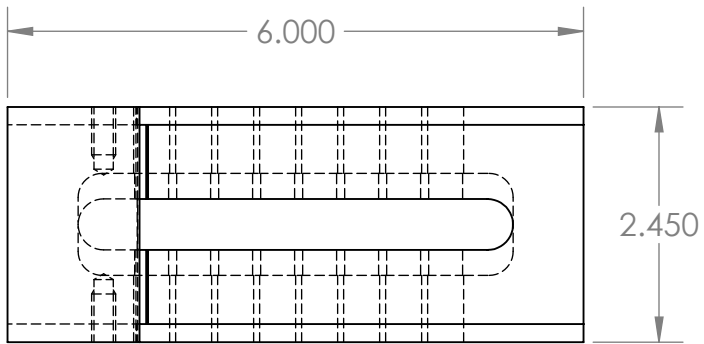

DETAIL A
SCALE 1 : 1

C

C

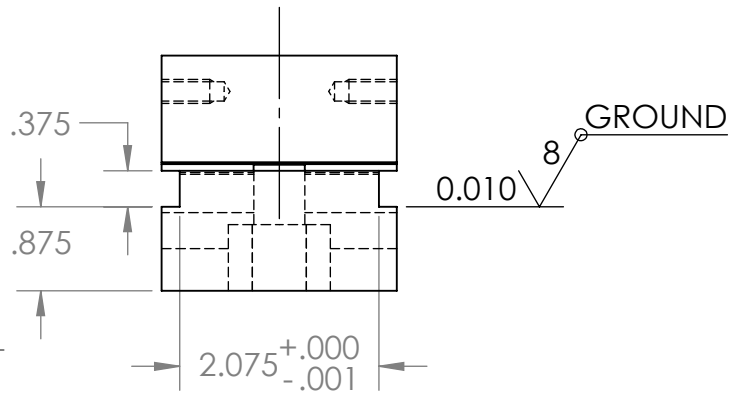
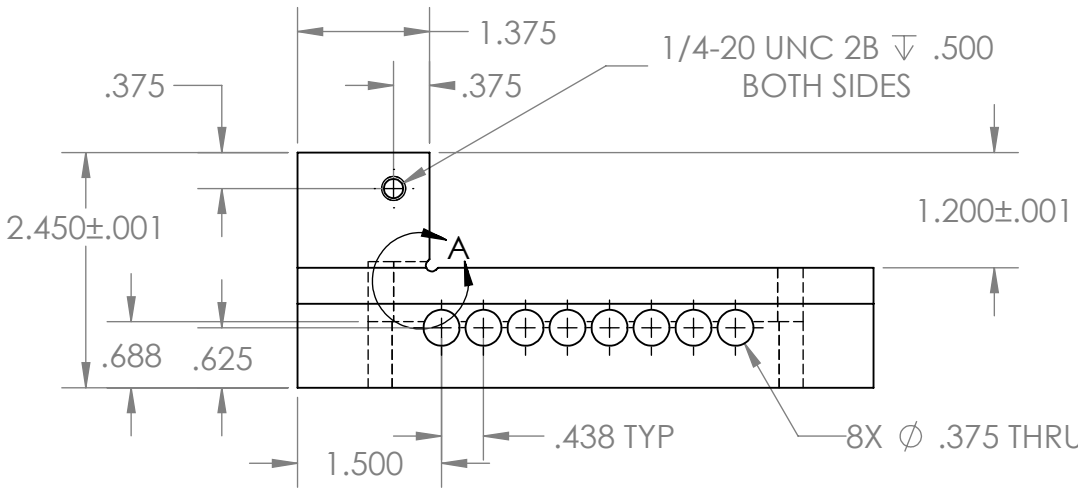

B

B

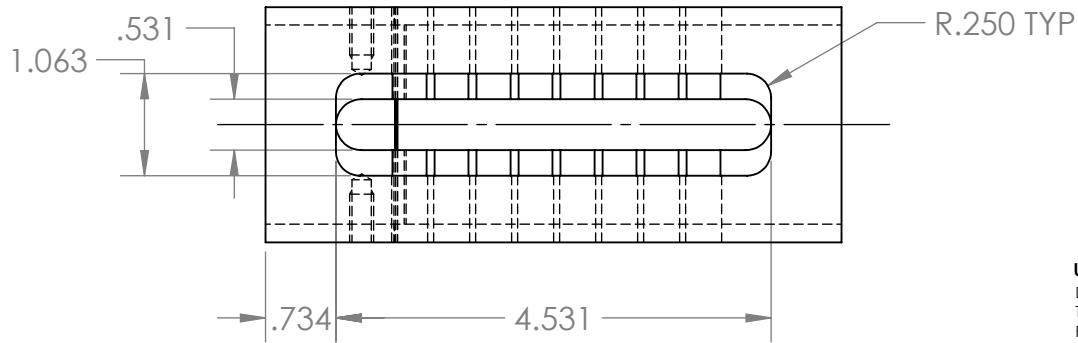

NOTES:
1. HEAT TREAT TO 58-60 HRC
2. SURFACE GRIND ALL OUTSIDE EDGES

PROPRIETARY AND CONFIDENTIAL
THE INFORMATION CONTAINED IN THIS DRAWING IS THE SOLE PROPERTY OF MAKEITFROMMETAL.COM. ANY NON-EDUCATIONAL REPRODUCTION IN PART OR AS A WHOLE WITHOUT THE WRITTEN PERMISSION OF MAKEITFROMMETAL.COM IS PROHIBITED.

UNLESS OTHERWISE SPECIFIED:
DIMENSIONS ARE IN INCHES
TOLERANCES:
FRACTIONAL ±1/16
ANGULAR: MACH ±0.5 BEND ±1
TWO PLACE DECIMAL ±0.01"
THREE PLACE DECIMAL ±0.005"

MATERIAL	A2 STEEL
FINISH	GROUND

TITLE: TOOLMAKER'S VISE BASE	
SIZE A	DWG. NO. 002
SCALE: 1:2	WEIGHT:
SHEET 2 OF 4	

4

3

2

1

A

A

4

3

2

1

D

D

C

C

B

B

A

A

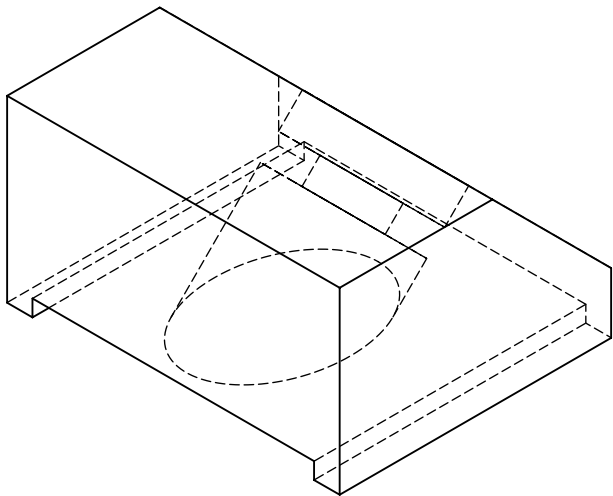

$\phi .500$ THRU
 $\square \phi 1.000 \nabla 0.250$

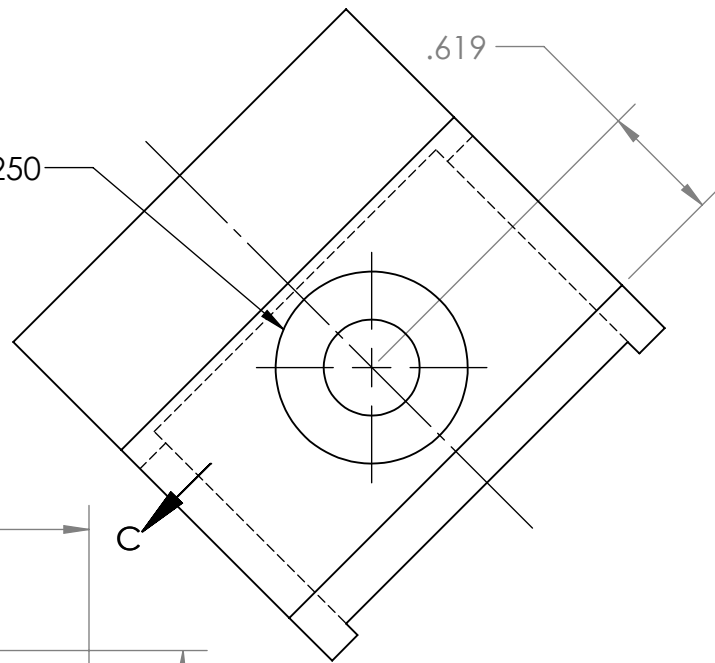

.619

C

VIEW C-C

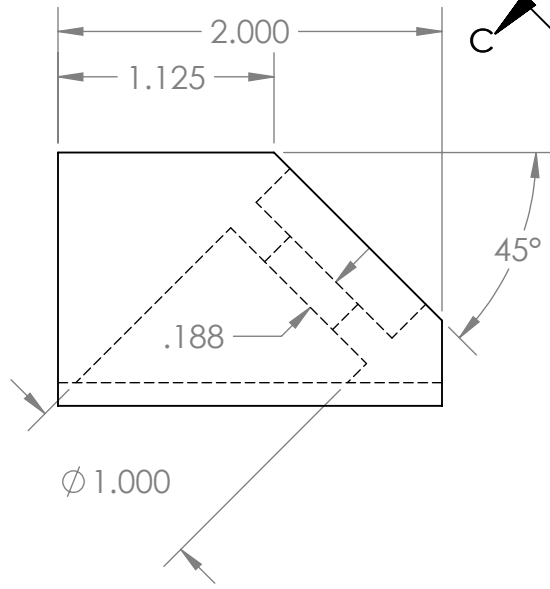

2.000

1.125

45°

.188

$\phi 1.000$

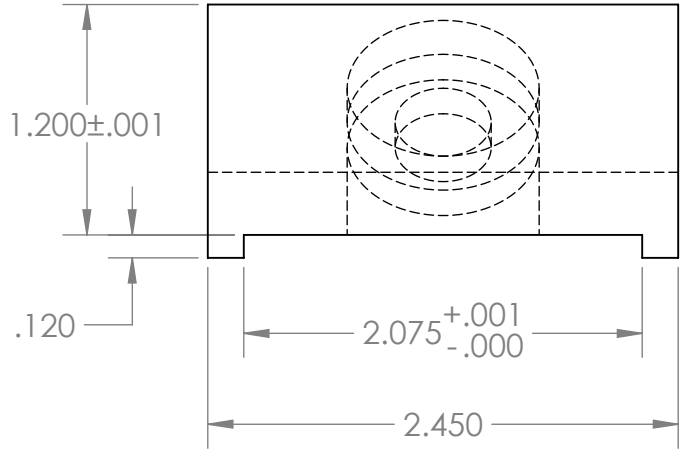

1.200 ± .001

.120

2.075 ^{+.001} _{-.000}

2.450

UNLESS OTHERWISE SPECIFIED:
 DIMENSIONS ARE IN INCHES
 TOLERANCES:
 FRACTIONAL ± 1/16
 ANGULAR: MACH ± 0.5 BEND ± 1
 TWO PLACE DECIMAL ± 0.01"
 THREE PLACE DECIMAL ± 0.005"

MATERIAL
A2 STEEL
 FINISH
GROUND

TITLE: TOOLMAKER'S VISE JAW			
SIZE A	DWG. NO. 003		
SCALE: 1:1	WEIGHT:	SHEET 3 OF 4	

PROPRIETARY AND CONFIDENTIAL
 THE INFORMATION CONTAINED IN THIS
 DRAWING IS THE SOLE PROPERTY OF
 MAKEITFROMMETAL.COM. ANY NON-
 EDUCATIONAL
 REPRODUCTION IN PART OR AS A WHOLE
 WITHOUT THE WRITTEN PERMISSION OF
 MAKEITFROMMETAL.COM IS
 PROHIBITED.

4

3

2

1

4

3

2

1

D

D

NOTE:
1. BREAK ALL SHARP EDGES 0.020" CHAMFER MAX

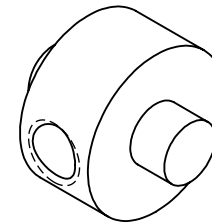

C

C

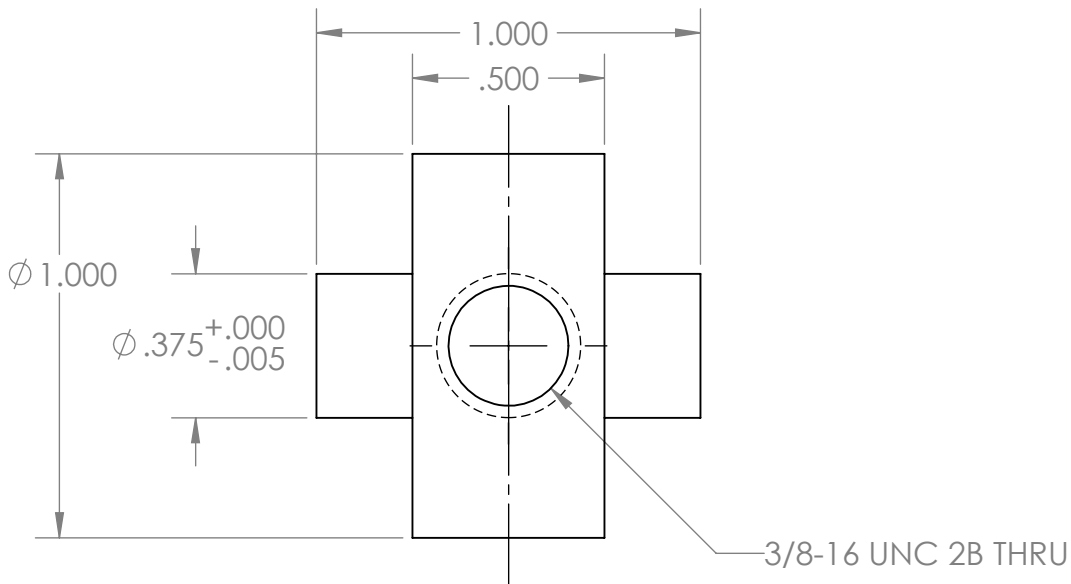

B

B

A

A

PROPRIETARY AND CONFIDENTIAL
 THE INFORMATION CONTAINED IN THIS
 DRAWING IS THE SOLE PROPERTY OF
 MAKEITFROMMETAL.COM. ANY NON-
 EDUCATIONAL
 REPRODUCTION IN PART OR AS A WHOLE
 WITHOUT THE WRITTEN PERMISSION OF
 MAKEITFROMMETAL.COM IS
 PROHIBITED.

UNLESS OTHERWISE SPECIFIED:
 DIMENSIONS ARE IN INCHES
 TOLERANCES:
 FRACTIONAL $\pm 1/16$
 ANGULAR: MACH ± 0.5 BEND ± 1
 TWO PLACE DECIMAL ± 0.01 "
 THREE PLACE DECIMAL ± 0.005 "

MATERIAL
4140 HTSR

FINISH
MACHINED

TITLE:
**TOOLMAKER'S VISE
 NUT**

SIZE DWG. NO.
A 004

SCALE: 2:1 WEIGHT: SHEET 4 OF 4

4

3

2

1